

Stray Light Analysis Using TracePro

Intuitive Interface, Enhanced Monte-Carlo Ray Tracing, Path Sorting, and strong CAD Import/Export

Stray light occurs in all optical and illumination systems. Stray light includes ghost images in lens systems, single and multiple scatter from optical and mechanical surfaces, as well as narcissus and self-emission in infrared systems. Ghost images occur when light rays reflect from lens surfaces and reach the image plane in an unwanted location. At any surface boundary, reflection, refraction, absorption, reflective scatter, and transmissive scatter all may occur, each contributing to stray light.

Stray light resulting from each phenomenon can be accurately predicted and analyzed using TracePro.

TracePro's advanced features provide insight into determining problematic stray light paths. You can visualize and quantify any individual stray light path, and use Boolean filters to group similar paths together. Rays from the paths can be displayed, as well as 2D and 3D irradiance maps resulting from the selected paths. The Flux Report details how much light is incident and absorbed on each surface and object. TracePro's strong interoperability enables import of lens design files, and import and export of standard CAD file formats.

With TracePro's ray splitting feature, a parent ray can be split into child rays (reflection, refraction, transmissive and reflective scatter, and absorption). Ray splitting enables efficient sampling of rays reflected from lens surfaces and is essential for ghost analysis.

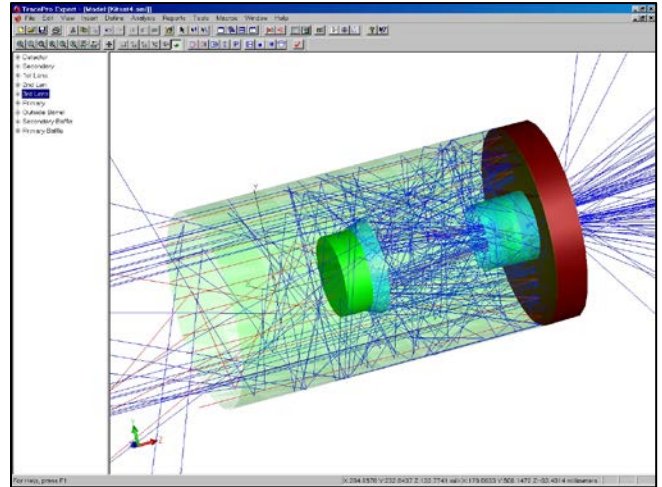

Figure 1: Cassegrain Telescope

TracePro's Monte Carlo ray tracing engine provides a powerful, general-purpose tool for simulation of optical phenomena as probability distributions, and uses pseudo-random numbers to sample these distributions. Variance reduction techniques are employed to improve simulation efficiency by orders of magnitude over crude Monte Carlo.

Importance sampling is a variance reduction method used to increase sampling in low-probability scattered paths that would otherwise be under-sampled. A scatter distribution function is used to determine probability density and apportion a fraction of the scattered ray flux into a desired direction. Importance sampling can speed convergence of the simulation by orders of magnitude.

TracePro provides an intuitive design environment combined with powerful Monte-Carlo simulation, scatter modeling, visualization and analysis features, and outstanding performance and accuracy.

Features

TracePro is used extensively for stray light analysis and related applications, including:

- Baffle design for stray light suppression
- Analysis of stray light due to scattering, aperture diffraction, and ghost images
- Self-emission of infrared and longer-wavelength systems
- Simulation of polarization effects including birefringence
- Simulation of spectrometers and other multi-spectral systems
- Thermal effects and loading
- Narcissus effects
- Diffraction gratings

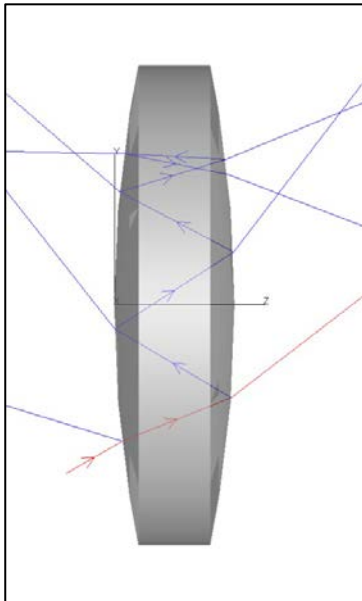

Figure 2: Ray splitting to track multiple reflections in a lens

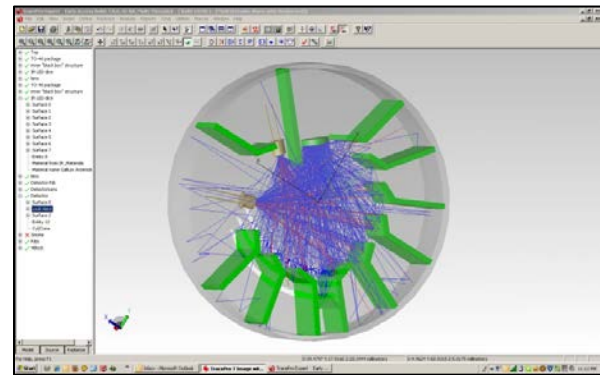
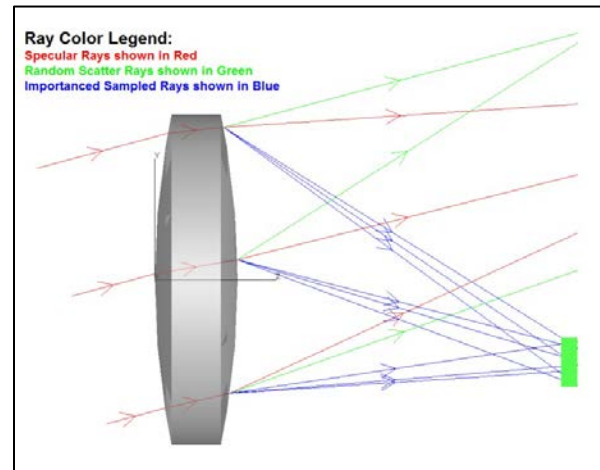

Figure 4: Stray light analysis of an optical smoke detector

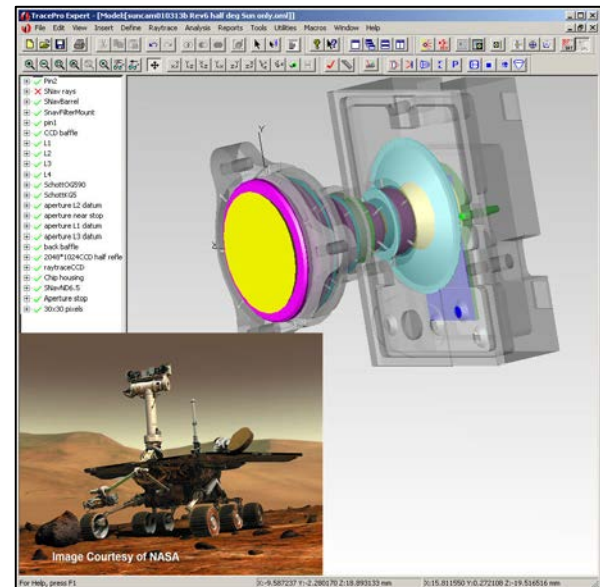

Figure 5: Mars Rover with TracePro model
Mars Rover photo courtesy of NASA.

REV 2018-09-21